

WASCOMAT W SERIES WASHERS

Rugged, reliable, built to last a generation
in any self-service laundry installation

The Wascomat W Series, solid-mount, front-load washers save water and energy and provide professional quality wash results.



Designed and built for the 21st Century!



W620 / 20 lb. cap.
Junior

W630 / 30 lb. cap.
Senior

W640 / 40 lb. cap.
Super Senior

W655 / 55 lb. cap.
Giant

W675 / 75 lb. cap.
Super Giant

W Series Features & Benefits

- Large door opening for easy loading and unloading.
- Hot, cold, warm, delicate and permanent press wash options to reduce time, water and energy use.
- Unibody construction eliminates welds for superior strength, reliability and durability.
- Unique wire harnesses with foolproof "quick disconnect" plugs simplify service.
- Interchangeable parts from one size and model washer to another.

Unique 4-Compartment Supply Dispenser

Accepts liquid or powder detergents, bleach and fabric softener for superior wash results that keep your customers coming back.



- 1 Easy service access to quick disconnect washer controls
- 2 Four-compartment supply dispenser
- 3 UPC compliant venting for external backflow prevention
- 4 Triple-seal, extra heavy-duty bearing & seal system for long life
- 5 High-grade stainless steel inner and outer drums for long machine life
- 6 State-of-the-art riveted frame design for a generation of reliable operation
- 7 No-weld, state-of-the-art special galvanized steel base frame prevents cracks and rust
- 8 English/Spanish instruction panel provides simple step-by-step operating instructions
- 9 User-friendly control panel features large, bright display
- 10 Heavy duty cast door and hinges
- 11 Large door opening for easy loading and unloading
- 12 Door lock system unlocks at the end of wash cycle
- 13 Front accessible, reliable, water-operated drain valve mounted directly to outer drum reduces water consumption, clogs and is easy to clean

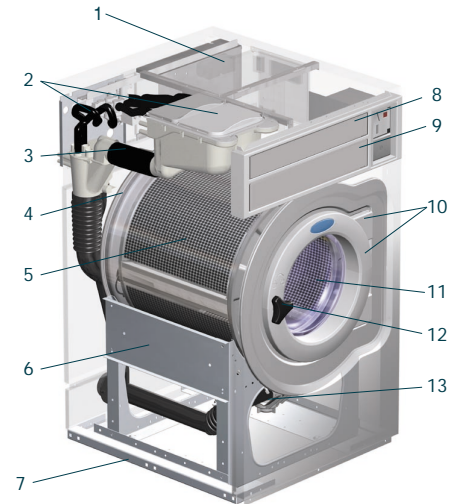

Choice of front panel colors: almond, teal green or white; stainless steel option.

Wascomat Laundry Equipment

The Standard of Quality for Over 100 Years!

Technical Specifications

Model	W620		W630		W640		W655		W675	
Capacity (lb/kg)	20	8.5	30	13	40	18	55	25	75	34
Width (in/mm)	26	660	28 3/8	720	29 1/2	750	32 11/16	830	35 13/16	910
Depth (overall) (in/mm)	30 1/8	765	32 1/2	825	36	915	39	990	42 5/16	1075
Height (in/mm)	43 7/8	1115	47 1/4	1200	52 3/16	1325	55 1/2	1410	56 7/8	1445
Crated width - (in/mm)	27 3/16	690	29 1/2	750	30 11/16	780	33 7/8	860	37	940
Crated depth - (in/mm)	32 11/16	830	35 1/16	890	39 3/16	995	43 11/16	1110	47 1/16	1195
Crated height - (in/mm)	48	1219	51 5/16	1304	56 7/16	1434	61 1/4	1556	62 7/16	1586
Height to bottom of door (in/mm)	14	355	14 3/8	365	17 1/8	435	19 1/2	495	19 11/16	500
Door opening diameter (in/mm)	12 3/16	310	14 3/8	365	15 9/16	395	17 1/8	435	17 1/8	435
Cylinder volume (ft ³ /l)	3.0	85	4.6	130	6.4	180	8.8	250	11.7	330
Cylinder diameter (in/mm)	20 1/2	520	23 7/16	595	25 9/16	650	28 9/16	725	31 5/16	795
Cylinder depth (in/mm)	16 5/16	414	18 7/16	468	21 5/16	542	23 7/8	606	26 3/16	665
Drain outlet diameter (in/mm)	2 or 3	50 or 75	2 or 3	50 or 75	3	75	3	75	3	75
Height to centerline of drain (in/mm)	3 15/16	100	3 15/16	100	3 15/16	100	3 15/16	100	5 1/2	140
Height to electrical connection (in/mm)	32 1/2	825	35 13/16	910	40 3/4	1035	44 1/8	1120	45 1/2	1155
Water connections (in/mm) (approx)	40 9/16	1030	43 7/8	1115	49	1245	52 3/8	1330	53 3/4	1365
Dynamic load (lb/kN)	+/-670	+/-3.1	+/-922	+/-4.1	+/-1192	+/-5.3	+/-1259	+/-5.6	+/-1320	+/-5.9
Dynamic frequency (Hz)	8.8		8.2		7.9		7.4		9.4	
Noise level (dBA)	66		68		80		80		80	
Net wt (lb/kg)	300	136	386	175	503	228	633	287	838	380
Crated weight (lb/kg)	331	150	419	190	540	245	672	305	882	400
Operating Speeds										
Wash (rpm)	52		49		44		44		42	
Extract (rpm/G-Force)	528 / 81		494 / 81		471 / 81		446 / 81		410/81	
Electrical Requirements (standard)										
Voltage/frequency/phase	208-240/60/3		208-240/60/3		208-240/60/3		208-240/60/3		208-240/60/3	
Full-load current (Amps) / Ckt breaker (Amps)	4.0 / 15		5.8 / 15		7.4 / 15		9.2 / 15		10.8 / 15	
Motor output - wash (hp/kW)	0.2 / 0.13		0.3 / 0.2		0.4 / 0.3		0.5 / 0.4		0.7 / 0.8	
Motor output - extract (hp/kW)	1.0 / 0.75		1.5 / 1.1		1.8 / 1.3		2.7 / 2.0		3.5 / 2.6	
Alternate Voltages										
Voltage/frequency/phase-breaker (rating)	120/60 (20A) 15A		208-240/60/1 (20A)		208-240/60/1 (25A)		208-240/60/1 (30A)		-	
	440/60/3 (10A)		440/60/3 (10A)		440/60/3 (10A)		440/60/3 (10A)		440/60/3 (10A)	
Water information										
Inlet fittings (* = 2 cold inlets)	DN20	3/4	DN20	3/4	DN20*	3/4*	DN20*	3/4*	DN20*	3/4*
Flow (gpm/lpm @ 45 psi) (each inlet)	5	20	5	20	5	20	16	60	16	60
Recommended water pressure (psi/kPa)	30-90	200-600	30-90	200-600	30-90	200-600	30-90	200-600	30-90	200-600

Classic Electromechanical Control



Choice of wash formulas – hot, cold, warm, permanent press and delicate with wash cycle options to reduce time, water and energy consumption (contact Wascomat for more information).

Choice of coin slide, drop coin meter or CashCard system.

Refer installation and servicing to qualified, licensed personnel. Always read installation and operating manuals and consult local codes before installation. Protect machines with properly rated, inverse-time, common-trip, industrial-type circuit breakers ONLY. Warranty void if not properly installed. Solid-mount machines require a custom concrete foundation, and are not suitable for upper-floor or above-basement installations. Contact Wascomat for more information and for availability of machines for electric services not listed. Specifications subject to change without notice. Wascomat assumes no responsibility for errors or omissions in this information.



For more information on the full line of Wascomat washers, dryers and low-cost financing, call Wascomat toll free today.

Your local independent authorized dealer

Wascomat Laundry Equipment

1-800-645-2204 • www.wascomat.com

461 Doughty Blvd., Inwood, L.I., N.Y. 11096-0338
 Sales and Administration – Tel: 516-371-4400 • Fax: 516-371-4204 • e-mail: sales@wascomat.com
 Spare Parts – Tel: 516-371-2000 • Fax: 516-371-4029 • e-mail: parts@wascomat.com
 Technical Support – Tel: 516-371-0700 • Fax: 516-371-4029
 En Mexico: Llame gratis a este numero 001-800-010-1010

